



APLAST
ROTOUOLDING
PIPING | TOOLING

Sewer inspection chambers



Content

About the company	4
Why choose the “Zagožen” type plastic chambers?	5
Inspection chambers with a double base	6
Standard inspection chambers	8
DN 625 inspection chambers	8
DN 800 inspection chambers	9
DN 1000 inspection chambers	10
Inspection chambers for high flow rates (chambers L, XL 2XL, 3XL)	11
DN 800 and DN 1000 collection chambers	12
Connection chambers (domestic chambers, sand traps, settlers)	13
Technical information about the inspection chamber	15
Modular elements of inspection chambers	16
Preparation of inspection chambers for installation	19
Examples of inspection chamber and sand trap installation	25
Testing and certification	27
Order form for “Zagožen” type inspection chambers	28
Order form for sand traps	29

About the company

One of the leaders

We are one of the leading companies for processing of plastic masses (rotomoulding) in Slovenia. We are actively entering western markets and at the same time sustaining our competitive advantage on the existing markets. We are successfully meeting pure strategic targets and following our mission and vision.

Mission

The company Aplast d.o.o. develops and manufactures products from plastic masses. In our own production facility we are manufacturing with the rotomoulding process:

- PE and PP chambers for sewerage and water distribution,
- PE and PP chambers for telecommunication cables,
- PE and PP chambers for electric power cables,
- Sandtraps,
- Oil traps,
- Biological waste water treatment plants,
- Water tanks,
- Septic tanks,
- Waste containers,
- Urn burial containers,
- Industrial programme.

The mission of the company APLAST and the main generator of our progress is to be a step ahead of the desires of our customers and owners and be environmentally friendly.

Vision

Our vision is to become and remain a company, which is always ahead of its competitors with its excellence on all levels of its endeavours, and which brings benefit to all its interested customers, employees and the people in the area, where we work.

Development

We are focused on the development of high quality and aesthetically pleasing products, which meet the basic requirements of quality, safety and efficiency. Therefore, we provide market advantage for the products under our own brand and recognisability in an ever more demanding circumstances.



Why choose the Zagožen type plastic chambers?

The inspection chambers of the "Zagožen" type is a multi-purpose chamber, designed for a wide range of applications.

The chamber is manufactured in accordance with the standard SIST EN 13598- 2:2009. Plastic piping systems for non-pressure underground drainage and sewage. The nominal diameter of the chamber is defined by its internal diameter, the chamber base is manufactured in accordance with the standard SIST EN ISO 3126.

Structural design of the chamber guarantees environmental suitability and also:

- Long life span (the life span of material is 50 years)
- Water tight,
- Resistance to waste water,
- Resistance to ageing,
- Resistance to wear and tear,
- Simple and quick height adjustment,
- Simple and quick installation of additional connections,
- Installation of various combinations of inlets and outlets,
- Savings in manufacture of the RC plate (cone),
- Appropriate for all types of sewage systems,
- Appropriate for all types of pipes,
- The height of the drain is equal to the max. diameter of a connecting pipe,
- Time saving due to quick and easy installation.

And because of low weight offers:

- Easy transportation,
- Simple handling (manual handling),
- Quick, simple assembly of chambers at the construction site



The inspection chamber, manufactured in accordance with the standard SIST EN 13598-2:2009, has to be declared according to the inner diameter of the chamber body! The inspection (control) chamber can be made with the chamber with inner chamber body diameter smaller than 800 mm (DN/ID \leq 800 mm). The minimal inner diameter for a chamber for occasional access should be DN/ID $>$ 800mm. For unlimited and unhindered access the chamber has to be in accordance with the requirements of the standard SIST EN 135982:2009 with the minimum inner diameter of DN/ID \geq 1000mm.

Gradient of thread surface is 1:20 according to DIN 4034 Part 1. Gradient of the chamber base is 1,5 %.

The height of the chamber base is larger than the max. dimensions of the inlet or outlet pipes according to DIN 4034 Part 1.

Inspection chambers with double base

Inspection chambers 5G DN 625, 800, 1000

Technical information:

Material: polyethylene or polypropylene.
 Chamber inner diameter: 625, 800, 1000.
 Diameters of sewage pipe connections:

> Chamber DN 625

- Standard inlet and outlet connections:
 $\varnothing 160$, $\varnothing 200$, $\varnothing 250$ or blank connection

> Chamber DN 800

- Standard inlet and outlet connections:
 $\varnothing 200$, $\varnothing 250$, $\varnothing 315$ or blank connection

> Chamber DN 1000

- Standard inlet and outlet connections:
 $\varnothing 250$, $\varnothing 315$, $\varnothing 400$ or blank connection

Option of additional connections on the body of the chamber:

- $\varnothing 63$ to $\varnothing 200$ with inlet gasket,
 larger diameters are welded

Minimum height: 0.5 m

Maximum height: 5.0 m or as requested.

Simple height adjustment.

Guaranteed watertight joints of chamber elements.

Connecting pipes:

- PVC smooth pipes,
- PE smooth and corrugated pipes,
- PP smooth and corrugated pipes,
- All other sewage pipes
 (ductile, polyester, AC and RC pipes, etc.).

Basic types of water channels:

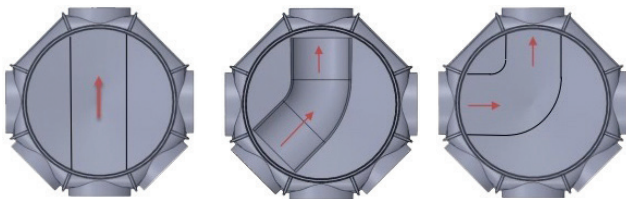

Combinations of inlet connections:

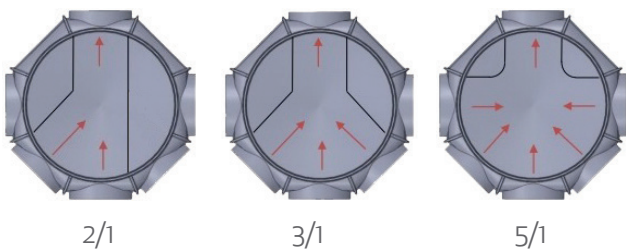

Water channel height is the same as the largest connecting dimension of the inlet pipe.



Standard inlet-outlet connections to the base of a 5G chamber

	DN 625			DN 800				DN 1000				
Inlet \ Outlet	160	200	250	160	200	250	315	160	200	250	315	400
160	•											
200	•	•		•	•							
250	•	•	•	•	•	•		•	•	•		
300				•	•	•	•	•	•	•	•	
400								•	•	•	•	•

Advantages of a double base chamber:

- Chamber base has a double wall (outer chamber wall and inner water channel wall).
- The outer wall of the chamber base prevents the deformation of the chamber water channel.
- The space between the outer chamber wall and the water channel can be filled with various fillings.
- The filling substantially improves the resistance of the chamber base to the hydrostatic pressure and thus prevents deformations of the chamber water channel.
- Installation of the chamber is also possible in areas with high groundwater (up to 5m).
- Great stability when placing the chamber in the excavation due to the flat base of the chamber.
- Easy backfilling of the chamber due to special version of the chamber base.
- The combination of inlet connections can easily be adapted to the requirements of the project.
- A possibility of making additional connections in the chamber base.
- Chamber water channel is completely smooth.
- The body of the inspection chamber can be made of reinforced rotomoulding rings or of PE/PP corrugated pipe.



Standard inspection chambers

DN 625 inspection chambers

Technical information

Material: polyethylene or polypropylene.

Chamber inner diameter: 625 mm.

Diameters of sewage pipe connections:

> 1/1 chamber

- Standard outlet connections:
PVC: $\varnothing 200$, $\varnothing 250$ and $\varnothing 315$
- Standard inlet connections:
 $\varnothing 160$, $\varnothing 200$, $\varnothing 250$ and $\varnothing 315$ or blank connection.

> 3/1 chamber

- Standard outlet connections:
PVC: $\varnothing 160$, $\varnothing 200$ and $\varnothing 250$
- Standard inlet connections:
 $\varnothing 160$, $\varnothing 200$ and $\varnothing 250$ or blank connection.

> 4G 1/1 chamber

- Standard outlet and inlet connections for corrugated pipes:
PVC: $\varnothing 160$, $\varnothing 200$, $\varnothing 250$ and $\varnothing 315$,
PE: $\varnothing 200$, $\varnothing 250$ and $\varnothing 300$,
PP: $\varnothing 200$, $\varnothing 250$ and $\varnothing 300$.

Option of additional connections on the body of the chamber:

- $\varnothing 63$ to $\varnothing 200$ with inlet gasket,
larger diameters are welded.

Minimum height: 0.5 m.

Maximum height: 4.0 m or as requested.

Simple height adjustment.

Guaranteed watertight joints of chamber elements.

Connecting pipes:

- PVC smooth and corrugated pipes,
- PE smooth and corrugated pipes,
- PP smooth and corrugated pipes,
- All other sewage pipes
(ductile, polyester, AC and AB pipes, etc.).

Water channel height is the same as the largest connecting dimensions of the inlet pipe.

Other connections also available upon request.



1/1

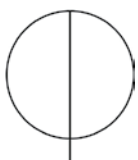

3/1

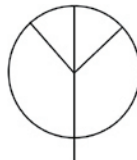

4G 1/1

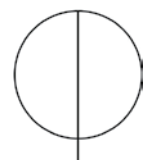

DN 800 inspection chambers

Technical information

Material: polyethylene or polypropylene.

Chamber inner diameter: 800 mm.

Diameters of sewage pipe connections:

> 1/1 chamber

- Standard outlet connections:
PVC: $\varnothing 250$, $\varnothing 315$ and $\varnothing 400$ for chamber,
- Standard inlet connections:
 $\varnothing 160$, $\varnothing 200$, $\varnothing 250$, $\varnothing 315$ and $\varnothing 400$ or blank connection.

> 3/1 chamber

- Standard outlet connections:
PVC: $\varnothing 200$, $\varnothing 250$ and $\varnothing 315$ for chamber,
- Standard inlet connections:
 $\varnothing 160$, $\varnothing 200$, $\varnothing 250$ and $\varnothing 315$ or blank connection.

> 4G chamber (1/1 and 1/1 45°)

- Standard outlet and inlet connections for corrugated pipes:
PVC: $\varnothing 200$, $\varnothing 250$, $\varnothing 315$ and $\varnothing 400$,
PE: $\varnothing 200$, $\varnothing 250$, $\varnothing 300$ and $\varnothing 400$,
PP: $\varnothing 200$, $\varnothing 250$, $\varnothing 300$ and $\varnothing 400$.

Option of additional connections on the body of the chamber:

- $\varnothing 63$ to $\varnothing 200$ with inlet gasket, larger diameters are welded.

Minimum height: 0,5 m.

Maximum height: 4,0 m or as requested.

Simple height adjustment.

Guaranteed watertight joints of chamber elements.

Connecting pipes:

- PVC smooth and corrugated pipes,
- PE smooth and corrugated pipes,
- PP smooth and corrugated pipes,
- All other sewage pipes (ductile, polyester, AC and AB pipes, etc.).

Water channel height is the same as the largest connecting dimensions of the inlet pipe.

Other connections also available upon request.



DN 1000 inspection chambers

Technical information

Material: polyethylene or polypropylene.

Chamber inner diameter: 1000 mm.

Diameters of sewage pipe connections:

> 1/1 chamber

- Standard outlet connections:
PVC: $\varnothing 250$, $\varnothing 315$ and $\varnothing 400$ for chamber,
- Standard inlet connections:
 $\varnothing 160$, $\varnothing 200$, $\varnothing 250$, $\varnothing 315$ and $\varnothing 400$ or blank connection.

> 3/1 chamber

- Standard outlet connections:
PVC: $\varnothing 250$, $\varnothing 315$ and $\varnothing 400$ for chamber,
- Standard inlet connections:
 $\varnothing 160$, $\varnothing 200$, $\varnothing 250$, $\varnothing 315$ and $\varnothing 400$ or blank connection.

> 4G chamber (1/1 and 1/1 45°)

- Standard outlet and inlet connections for corrugated pipes:
PVC: $\varnothing 200$, $\varnothing 250$, $\varnothing 315$ and $\varnothing 400$,
PE: $\varnothing 200$, $\varnothing 250$, $\varnothing 300$ and $\varnothing 400$,
PP: $\varnothing 200$, $\varnothing 250$, $\varnothing 300$ and $\varnothing 400$.

Option of additional connections on the body of the chamber:

- $\varnothing 63$ to $\varnothing 200$ with inlet gasket, larger diameters are welded.

Minimum height: 0.5 m.

Maximum height: 4.0 m or as requested.

Simple height adjustment.

Guaranteed watertight joints of chamber elements.

Connecting pipes:

- PVC smooth and corrugated pipes,
- PE smooth and corrugated pipes,
- PP smooth and corrugated pipes,
- All other sewage pipes
(ductile, polyester, AC and AB pipes, etc.).

Water channel height is the same as the largest connecting dimensions of the inlet pipe.

Other connections also available upon request.



1/1

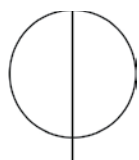

3/1

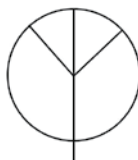

4G 1/1

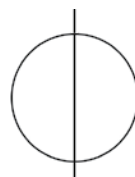

4G 1/1 45°

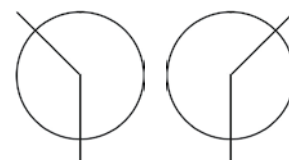

Inspection chambers for high flow rates

Technical information

Material: polyethylene or polypropylene.

Chamber inner diameter: 800 mm (L) or 1000 mm (XL, 2XL, 3XL)

Diameters of sewage pipe connections:

> L chamber

- Standard outlet connections:
PVC, PE, PP
ø500 and ø600
- Standard inlet connections:
PVC, PE, PP
ø500 and ø600 or blank connection

> XL chamber

- Standard outlet connections:
PVC, PE, PP
ø500 and ø600
- Standard inlet connections:
PVC, PE, PP
ø500 and ø600 or blank connection

> 2XL chamber

- Standard outlet connections:
PVC, PE, PP
ø800
- Standard inlet connections:
PVC, PE, PP
ø800 or blank connection

> 3XL chamber

- Standard outlet connections:
PVC, PE, PP
ø1000
- Standard inlet connections:
PVC, PE, PP
ø1000 or blank connection

Option of additional connections on the body of the chamber:

- ø63 to ø200 with inlet gasket, larger diameters are welded.

Chamber flow base

Minimum height:

- XL and L chambers - 0,75 m
- 2XL chamber - 1,00 m
- 3XL chamber - 1,25 m

Maximum height: 4,0 m or as requested.

Simple height adjustment.

Guaranteed watertight joints of chamber elements.

Connecting pipes:

- PVC smooth and corrugated pipes,
- PE smooth and corrugated pipes,
- PP smooth and corrugated pipes,
- All other sewage pipes (ductile, polyester, AC and AB pipes, etc.).

Water channel height is the same as the largest connecting dimensions of the inlet pipe

Other connections also available upon request.



L chamber



XL chamber



2XL chamber



3XL chamber

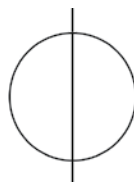

DN 800 and DN 1000 collection chambers

Collection chambers are designed for use on steep slopes, for the so called "mountain sewer", where the use of high cascade chambers is not economical. The specifically designed base and tangential inlet neutralise the impact of the water mass and reduce the speed of the flow.

Technical information

Material: polyethylene or polypropylene.
 Chamber inner diameter: 800 or 1000 mm.
 Standard gradient of inlet and outlet connections 10°.
 Simple height adjustment.
 Guaranteed watertight joints of chamber elements.

Connecting pipes:

- PVC smooth and corrugated pipes,
- PE smooth and corrugated pipes,
- PP smooth and corrugated pipes,
- All other sewage pipes (ductile, polyester, AC and AB pipes, etc.).

		DN 800			DN 1000		
Outlet	Inlet	160	200	250	200	250	315
	160		•				
200		•	•		•		
250		•	•	•	•	•	
315					•	•	•

The basic collection chamber is without the inlet-outlet connection for a suitable pipe.



DN 1000 chamber



DN 800 chamber

The collection base is connected to the body of the collection chamber through a gasket. This enables a simple angle adjustment between the inlet and outlet.

Connection chambers

Domestic connection chambers

Material: polyethylene or polypropylene.

DN	Height (mm) *	Outlet (DN)
400	500	110
400	750	110
400	1000	110
400	500	160
400	1000	160
400	1500	160
500	1000	160
500	1250	160
500	1500	160
500	2000	160
500	1000	200
500	1250	200
500	1500	200
625	500	160/200
625	750	160/200
625	1000	160/200
625	1250	160/200
625	1500	160/200
625	1750	160/200
625	2000	160/200

* Standard heights

Domestic chamber height can be adjusted.

Water channel height is the same as the largest connecting dimensions of the inlet pipe.

Option of additional connections on the body of the chamber:

- $\varnothing 63$ to $\varnothing 200$ with inlet gasket, larger diameters are welded.



Domestic chamber DN 400/110



Domestic chamber DN 400/160
DN 500/160



Domestic chamber DN 625/200

Sand traps / Settlers

Material: polyethylene or polypropylene.

DN	Height (mm)
400	500
400	1000
400	1500
400	1750
400	2000
500	1000
500	1250
500	1500
500	1750
500	2000
625	500
625	1000
625	1500
800	750
800	1000
800	1250
800	1750
800	2000
1000	750
1000	1000
1000	1250
1000	1500
1000	1750



Sand trap DN 400, DN 500 and DN 625



Sand trap DN 800 without a cone



Sand trap DN 1000 with a cone

* Standard heights

Sand trap height can be adjusted.

We manufacture various connecting pipes with an inlet gasket up to $\varnothing 200$ or with a welded connection for all types of sewage pipes.

Sand traps DN800 and DN1000 can be concluded with a cone of the inlet opening DN625.

Technical information about the inspection chamber

Standard inlet-outlet connections to the base of the chamber 1/1

	DN 625				DN 800					DN 1000				
Inlet / Outlet	160	200	250	315	160	200	250	315	400	160	200	250	315	400
200	•	•												
250	•	•	•		•	•	•			•	•	•		
315	•	•	•	•	•	•	•	•		•	•	•	•	
400					•	•	•	•	•	•	•	•	•	•

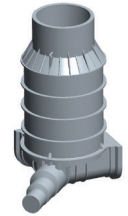

3/1

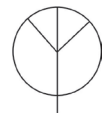

Standard inlet-outlet connections to the base of the chamber 3/1

	DN 625			DN 800				DN 1000				
Inlet / Outlet	160	200	250	160	200	250	315	160	200	250	315	400
160	•											
200	•	•		•	•							
250	•	•	•	•	•	•		•	•	•		
315				•	•	•	•	•	•	•	•	
400								•	•	•	•	•

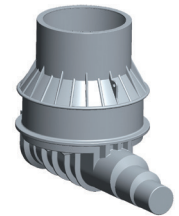

1/1

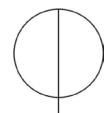

Other connections by request.

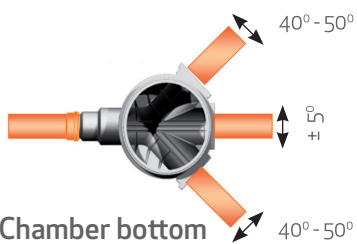

Inlet connections made with inlet gaskets enable offset of connectors for $\pm 5^\circ$.

Chamber bottom

Standard inlet-outlet connections to the base of 4G chamber -1/1 and 1/1 45°

	DN 625			DN 800				DN 1000			
Inlet / Outlet	200	250	300	200	250	300	400	200	250	300	400
200	•	•									
250	•	•	•	•	•	•		•	•	•	
300	•	•	•	•	•	•	•	•	•	•	•
400				•	•	•	•	•	•	•	•

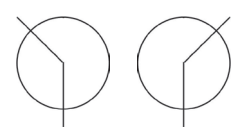
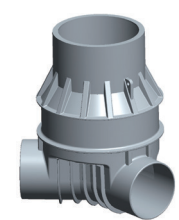
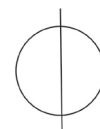
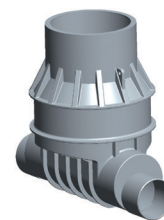

Modular elements of an inspection chamber

Option of assembly of an inspection chamber on site from individual elements.

Material: polyethylene or polypropylene.

Chamber base

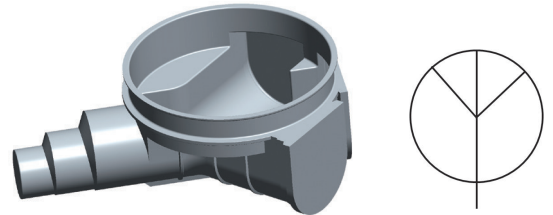
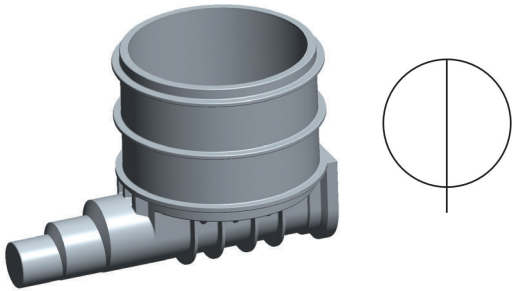

Base (DN)	Height (mm)
625	500
625	750
625	1000
800	500
800	750
800	1000
800	1250
800	1500
800	1750
1000	500
1000	750
1000	1500
1000	1750

Base (DN)	Height (mm)
625	500
625	750
625	1000
800	500
800	750
800	1750
1000	500
1000	750
1000	1500

Chamber ring

Ring (DN)	Height (mm)
400	250
500	250
625	250
625	500
800	500
800	750
1000	500
1000	1000



Chamber cone

Cone (DN)	Height (mm)
800	500
800	750
1000	750
1000	1000

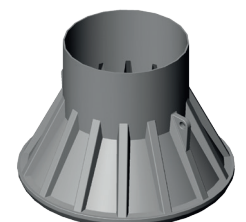
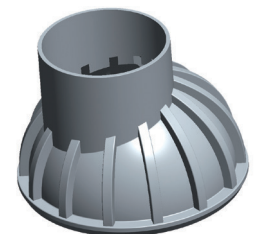

PE covers

Material: polyethylene, polypropylene.

DN 400

DN 500

DN 625



In case of a waterproof or odourless cover, an appropriate seal is used.

PE cover - cupola

Material: polyethylene, polypropylene.

DN 800

DN 1000



Special editions of PE covers

Vent on a PE cover or cupola



Chamber seal

DN 400

DN 500

DN 625

DN 800

DN 1000

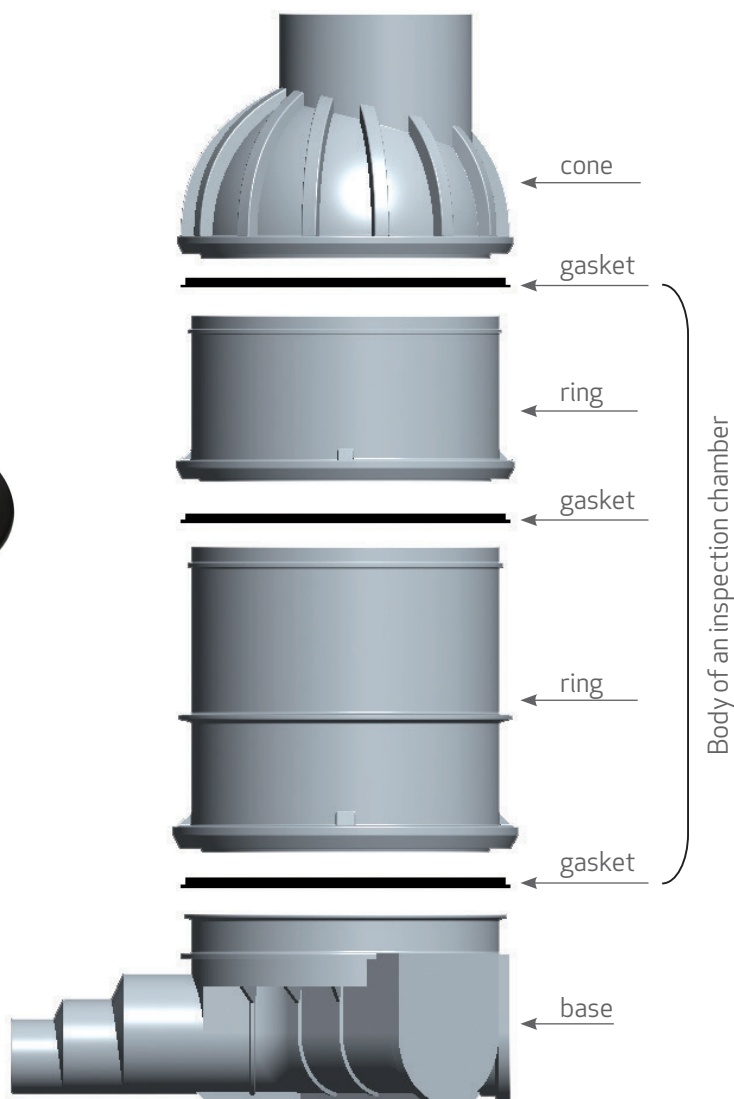

KS inlet gaskets

Dimensions: \varnothing 50 mm, \varnothing 63 mm, \varnothing 75 mm, \varnothing 90 mm, \varnothing 110 mm, \varnothing 160 mm, \varnothing 200 mm, \varnothing 250 mm, \varnothing 315 mm, \varnothing 400 mm.



DN	Drilling \varnothing	Outer gasket \varnothing
50	57	100
63	70	100
75	83	110
90	98	125
110	124	160
125	138	175
160	175	210
200	215	245
250	265	300
315	330	360
400	415	450

LKS inlet gaskets

Dimensions: \varnothing 110 mm, \varnothing 125 mm, \varnothing 160 mm, \varnothing 200 mm.



DN	Drilling \varnothing	Outer gasket \varnothing
110	138	175/140
125	151	170/155
160	186	220/190
200	226	260/230

Hole saw cups

Dimensions: \varnothing 63 mm, \varnothing 75 mm, \varnothing 90 mm, \varnothing 110 mm, \varnothing 160 mm, \varnothing 200 mm, \varnothing 250 mm, \varnothing 315 mm, \varnothing 400 mm.
Adapter.



LKS hole saw cups

Dimensions: \varnothing 110 mm, \varnothing 125 mm, \varnothing 160 mm, \varnothing 200 mm.
Adapter.



Preparation of inspection chamber for installation

Chamber assembly



Skim and clean the rim



Attach and lubricate the gasket



Attach the riser and cut off the rim



Attach the plate and apply pressure

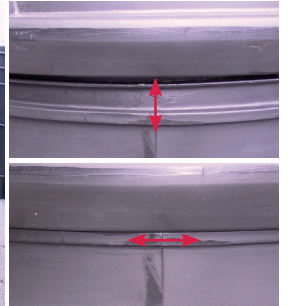

Before (above) and after applying pressure (below)

With the PE modular elements and suitable gaskets assembly on site is simple and easy. The chamber height is easily adjusted to the actual requirements. To assemble the chamber you also need a hand held scroll jigsaw, suitable lubricant and a tool for pressing the elements together. In the field you can use a smaller excavator to press the elements together. Before applying the pressure insert a wooden plate to equally distribute the pressure along the chamber riser rim.



Attach and lubricate the gasket, assemble cone



Chamber is ready for installation

Procedure for installation of an inlet for smooth PVC pipes:



Drill the inlet with suitable hole saw cup, adapter, adapter and handheld drilling machine



Clean the outer and inner rim of the hole



Install the inlet gasket



Lubricate the inlet gasket and PVC pipe



Attach the pipe to the chamber

Connection, made with an inlet gasket, can be adjusted for $\pm 5^\circ$.

Procedure for installation of an outlet for smooth PVC pipes:



Cut off the extension



Cut off the rim for 15mm/30°



Lubricate the rim...



... and the PVC pipe and gasket



Attach the PVC pipe

Connections to the chamber that ensure watertightness can be quickly and easily made on the site. The height and inlet angle can be adjusted.

Procedure for inlet and outlet connection with corrugated pipes on 4G and 5G chambers

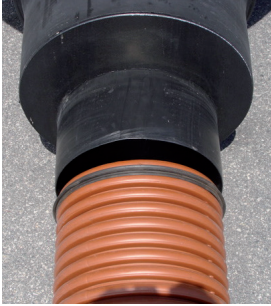

Place gasket on pipe (according to instructions by the pipe manufacturer)



Properly lubricate the interior of the connection and the gasket, push the pipe into the chamber



Place gasket on pipe. Properly lubricate the connection and the gasket. Push the pipe into the chamber.

Making an additional connection with a KS inlet gasket

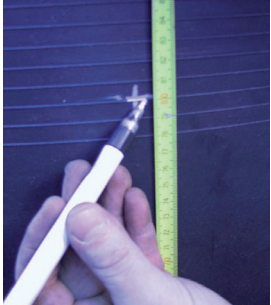

Determine the medium height of the additional connection

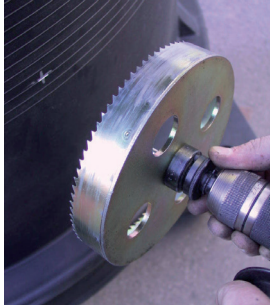

Drill a hole for a KS inlet gasket

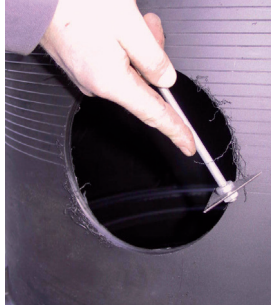

Clean and lubricate the rim



Insert the KS inlet gasket



Connect the PVC pipe

Making an additional connection with a LKS inlet gasket



Determine the medium height of the additional connection



Drill a hole for a LKS inlet gasket



Clean and lubricate the rim



Insert the LKS inlet gasket



Connect the PE corrugated pipe with PE coupling socket

Other sewage pipes can be connected with couplings



Male coupling for corrugated PVC pipe inlet



Female coupling for corrugated PVC pipe outlet



Male coupling for corrugated PE pipe

Installation details for PVC, PE, PP pipes

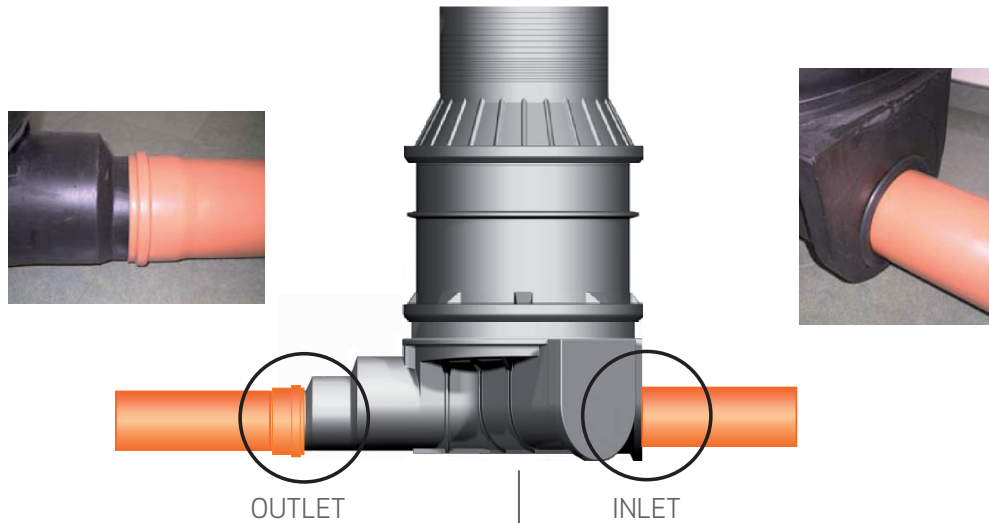

for PVC smooth pipes

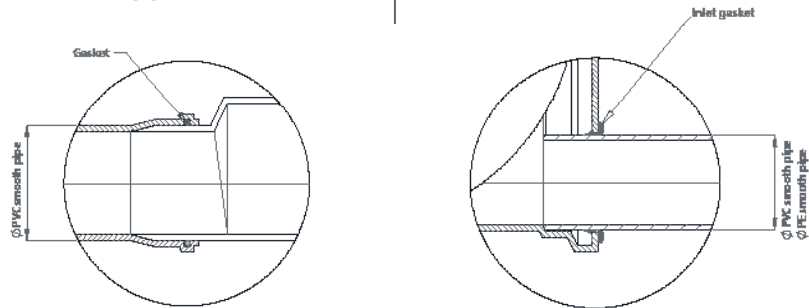

for PE and PP corrugated pipes

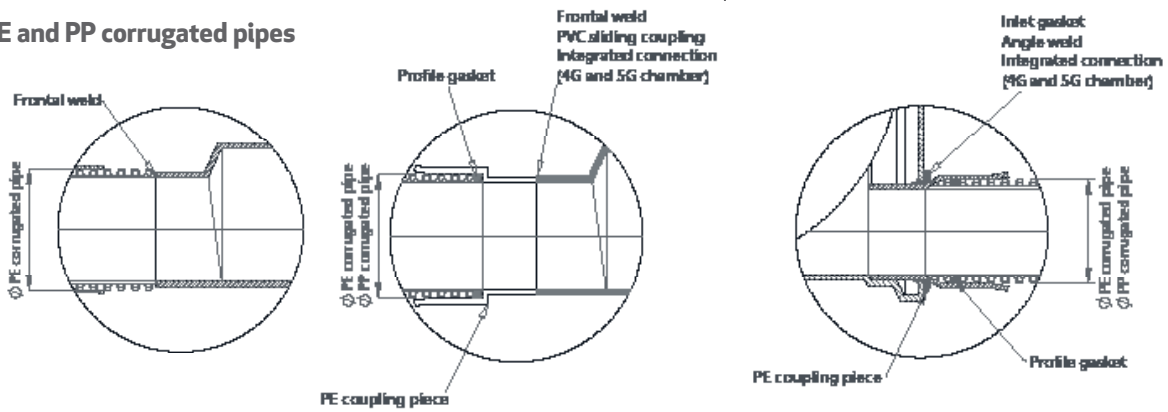

for PE smooth pipes

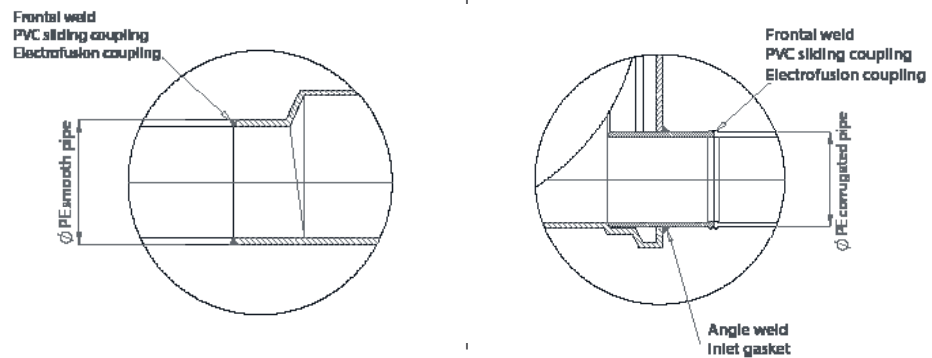

Preparation of foundation

The “Zagožen” type inspection chamber must be installed on a suitable foundation. It has to be hard and compact. Use suitable filling material.

Grained material may be of size from 0 to 32 mm, crushed material of size from 0 to 16 mm. Do not use frozen material.

The foundation has to be prepared in a layer of 15-20 cm and compressed up to 97 % by Proctor.

In the case of presence of groundwater the foundation has to be made of the MB15 concrete.

Installation of the chamber

Due to low weight the manual installation is possible. In case of machine handling bands may be tied around the chamber base or around hooks on the chamber cone.

Before placing the chamber in the pithole, check if the inlet gasket is clean and properly oriented. If there is any dirt on the inlet gasket and outlet coupling, they should be cleaned thoroughly beforehand.

Use suitable lubricant for pipes and gaskets for easier assembly.

Chamber backfill

Backfilling of the “Zagožen” type installation chamber requires the use of appropriate material (the same as for the foundation) and the correct implementation. The backfilling material must be carefully compacted up to the 97 % of Proctor in layers (up to 30 cm thick) in the area in the radius of at least 50 cm from the wall of the chamber.

Special attention should be given to the area below the base of the chamber. All of the empty space must be filled and compacted with hand tools in order to prevent subsequent deformations to the chamber base.

The project manager selects the appropriate type of inspection chamber.

Inspection chambers have to be properly anchored due to buoyancy according to the instructions of the project manager.

With chambers L, XL, 2XL and 3XL, it is required to backfill with a layer of concrete, according to the instructions of the project manager.

In case of groundwater the space around the chamber has to be backfilled with concrete if the groundwater height is > 2m, or > 5m with 5G chambers.

During backfilling the module “Zagožen” type inspection chamber heavy machinery should not be driven over the chamber or over the immediate area of the backfill.



Height adjustment

The height of the chamber is adjusted to the terrain with simple cutting of the chamber cone. Factory made markings on the cone provide for level cut.

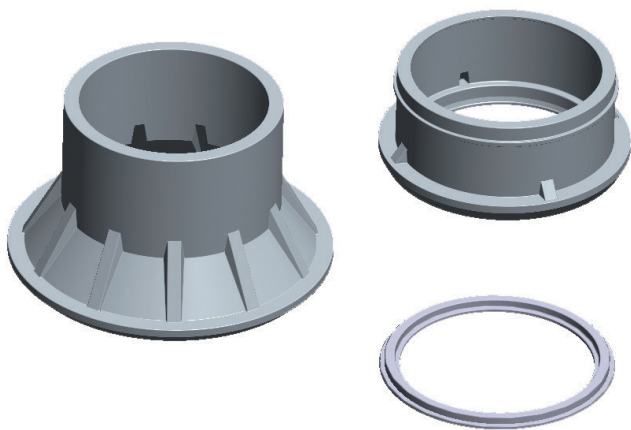

The chamber can be extended. The rim of the cone is cut off, a gasket is attached, lubricated and a cone extension of a max. height of 250 mm is installed. Another method is to remove the cone from the body, which can then be extended with a suitable riser.

The DN 800 h=750 mm and DN 1000 h=1000 mm cones, which are already extended, should not be extended any further.

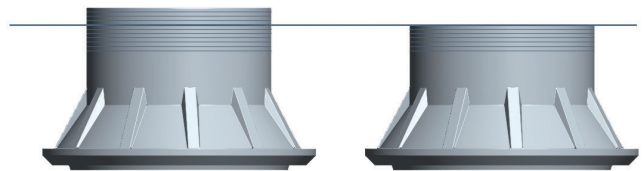

Installation of PE cast iron cover

The chamber can be covered with covers for direct installation:

- PE cover



- Cast iron cover of the A50 type or B125 type, no additional RC ring required.



Cast iron covers for direct installation are especially suitable for installation on farming areas, where we have to watch out for farming mechanisation and at the same time degrade useful surface as little as possible.

Before installing of the chamber in a heavy traffic area it must be taken into account that the RC ring and the plate do not rest on top of the chamber. The distance between the top of the chamber and finished RC ring or the lower rim of the cast iron cover has to be min. 50 mm. Thus the static and dynamic loads do not transfer directly to the body of the chamber, but rather on the backfilling material around the chamber.

Minimum recommended dimensions of the RC ring and installation

Chamber diameter DN	625	800	1000
RC ring diameter (mm)	1025	1200	1400

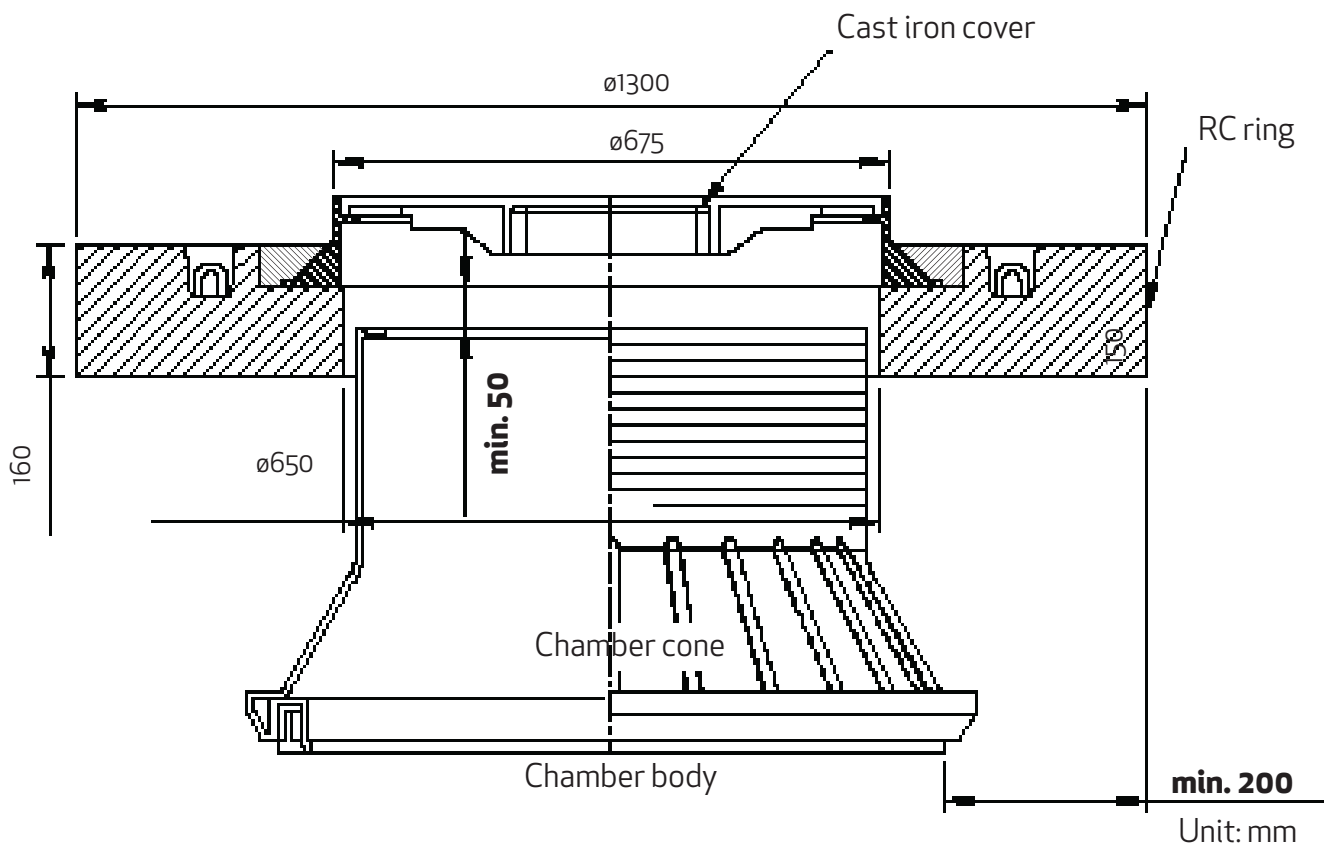

***The correct dimensions of the RC ring and RC plate are specified by the project manager with respect to the load bearing capacity of the cast iron cover and the surface loads.**

Examples of inspection chamber and sand trap installation



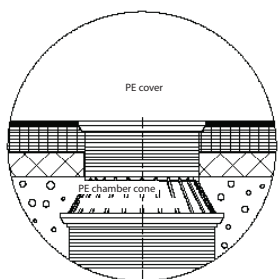
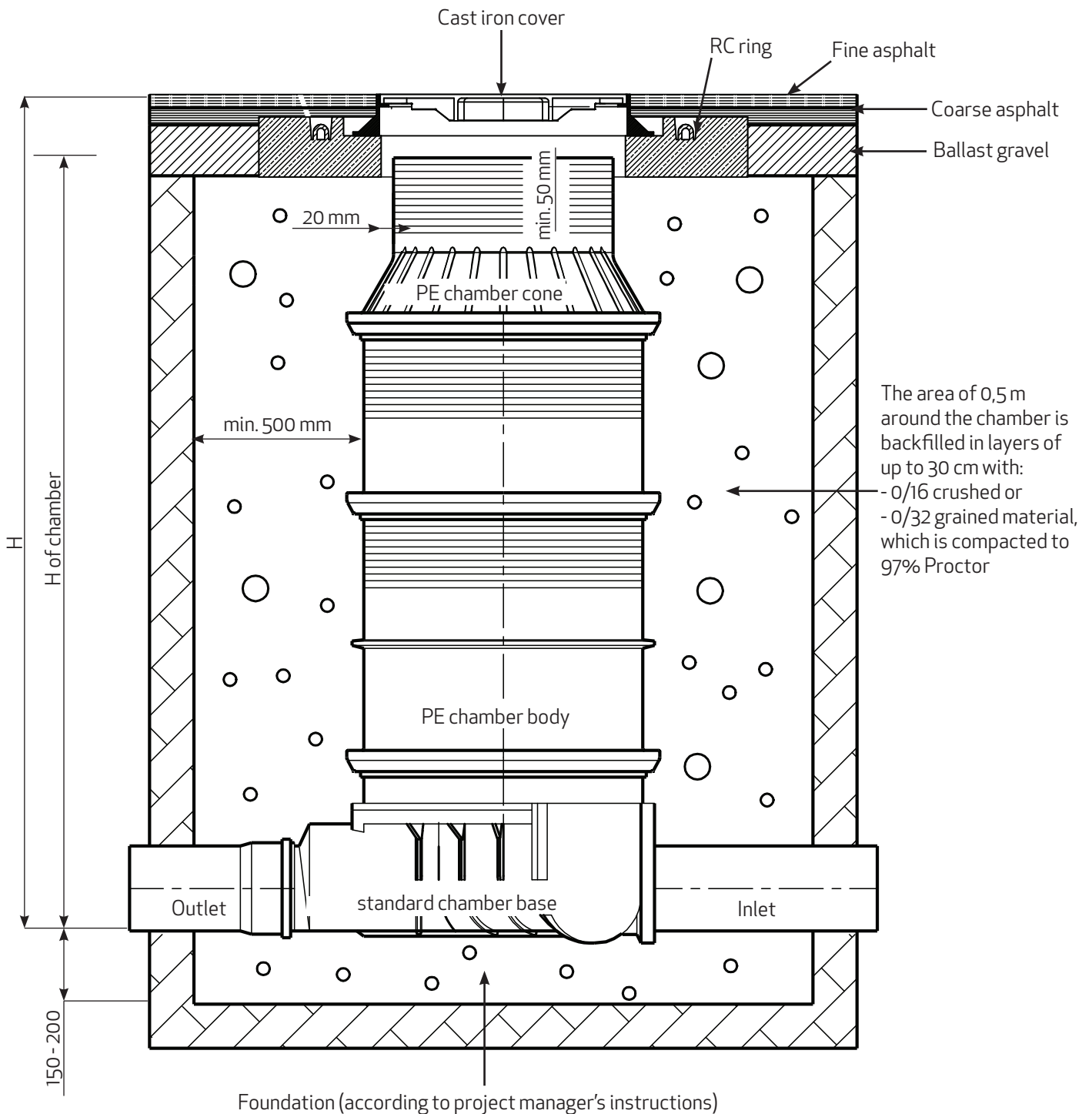

Installation detail for PE chamber on grassy surfaces

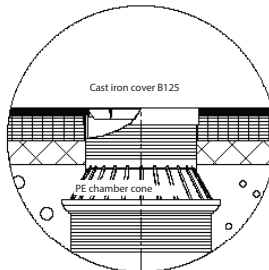

Installation detail for PE chamber with cast iron cover B125 - CLASS B direct loading

Testing and certification

We monitor the quality of products at every step of our manufacturing process. All shipments of raw materials, as well as the products at each production phase are monitored and inspected in detail.

The PE "Zagožen" type chambers have the SLOVENIAN TECHNICAL APPROVAL STS07/114.

The PE "Zagožen" type sand traps have the SLOVENIAN TECHNICAL APPROVAL STS07/115.

The "ZAGOŽEN" type inspection chamber has a suitable report on conformity issued by the authorised institutions of ZAG Ljubljana.

The company APLAST d.o.o. operates under the regulations set forth in the ISO 9001/2008 quality standard and in accordance with the requirements of the environment treatment standard ISO 14001/2004.

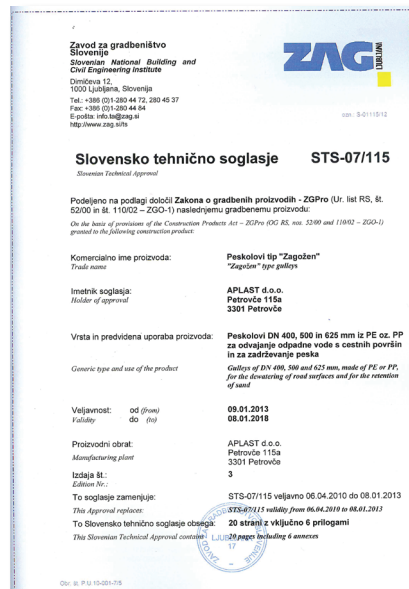
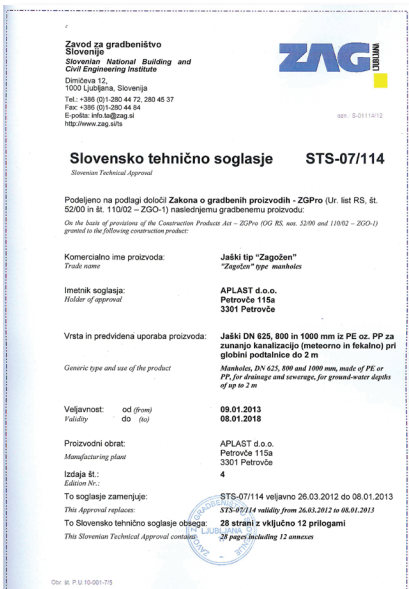

Order form for Zagožen type inspection chambers

The form is available at your retailer.



PE INSPECTION CHAMBER "ZAGOŽEN" TYPE-

Dimensions for making a **STANDARD** chamber:

Facility: SAMPLE SEWAGE Date of manufacture: (ZAGOŽEN) NDN: (ZAGOŽEN)

Obr. 72/12

Decline (%)	H(m) of underground water	
	inlet	outlet
5	5	0,5
5	5	0,5
5	5	0,5
5	5	0,5

No.	Name of the chamber	DN of the chamber (mm)	Height H (mm)	Inlets			Outlet D4 (mm)	No. of pieces	Water channel
				D1 (mm)	D2 (mm)	D3 (mm)			
1	J1	800	1500	200G	250G	/	250G	3	3/1
2	J2	1000	2250	/	250G	/	250G	1	1/1
3	J3	800	1250	/	/	250PR	250PR	1	4G/45°
4	J4	1000	2000	/	250PR	/	250PR	2	4G
5									
6									
7									

→ for inlets and outlets is **OBLIGATORY** to mark which type of the pipe is needed - from the legend
 → pipes which are connected to the chamber can be adjusted for ±5°

No.	NOTE:
1	d.p. 160G, H= 550mm, alfa=90°
2	/
3	/
4	d.p. 250PR, H= 900mm, alfa=256°
5	
6	
7	

Legend:

- GA – PVC Alvehol
- G – PVC smooth pipe
- PG – PE smooth pipe
- PR – PE corrugate pipe
- PP – PP corrugate pipe

NOTE:

* Bottom of the chamber has a decline of 1,5%!
 - other declines are charged extra!

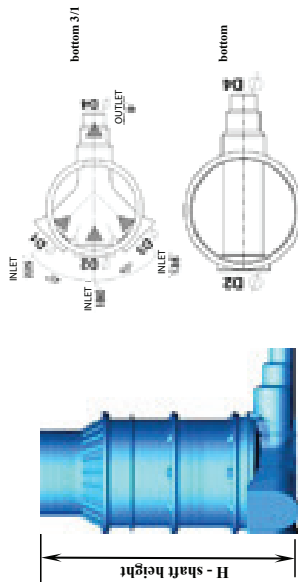

Date: _____ Customer: _____ Signature: _____

APLAST proizvodnja in trgovina d.o.o.
 Petrovče 115a,
 3301 Petrovče, Slovenija
 t | +386 (0) 3 713 24 50
 f | +386 (0) 3 713 24 54
 e | info@aplast.si
 w | www.aplast.si



Order form for sand separators

The form is available at your retailer.



Obr. 72/10

PE SANDSEPARATOR ORDER FORM

a) REGULAR

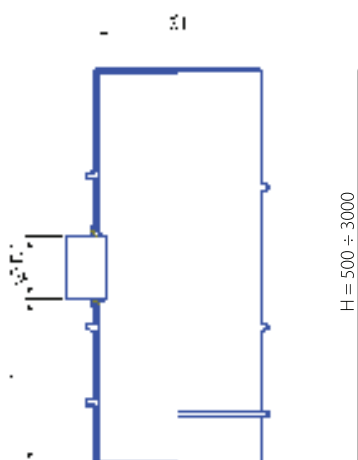

b) ODOURLESS

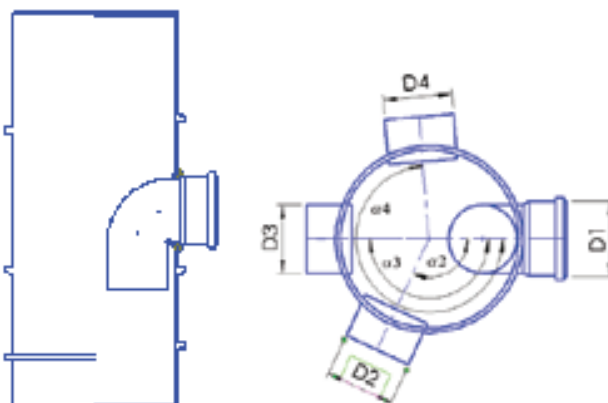

When ordering, it is **OBLIGATORY** to fill out the following dimensions:
SANDSEPARATOR no. P1

Diameter of sandseparator **D:** 400 (mm)

Height of sandseparator **H:** 1000 (mm)

Diameter of outlet **D1:** 160G (mm)

Height of outlet **H1:** 500 (mm)

Additional outlets:

Outlet	Diameter(mm)	Height (mm)	Angle α°
D2	ϕ 160G	H2= 500	$\alpha_2 = 180^\circ$
D3	ϕ	H3=	$\alpha_3 =$
D4	ϕ	H4	$\alpha_4 =$

NOTE:
 Angle of a dditional outlet is measured from D1 clockwise.

NUMBER OF THE SAME SANDSEPARATORS: 2 pcs

Date: 29. 8. 2016

Customer: Company or Name and Surname

Signature:

APLAST proizvodnja in trgovina d.o.o.
 Petrovče 115a,
 3301 Petrovče, Slovenija

t | +386 (0) 3 713 24 50
 f | +386 (0) 3 713 24 54
 e | info@aplast.si
 w | www.aplast.si





APLAST proizvodnja in trgovina d.o.o.
Petrovče 115a, 3301 Petrovče, Slovenija
www.aplast.si | info@aplast.si



YOUR RETAILER: