



APLAST
ROTOMOULDING
PIPING | TOOLING

AQUAoil OIL AND GREASE SEPARATORS



Protect the groundwater - intercept pollutants

AQUAoil oil separators are used for the separation of meteoric water from light liquids in the form of fuels and oils (< 0.95 kg/l), which constitute a threat in terms of groundwater pollution. Especially in the vicinity of:

- Petrol stations,
- Large multi-storey car parks,
- Car parks for transport vehicles,
- Car and tyre repair shops and car washes,
- As well as restaurants, oil and grease separators are statutory.

Greases must be filtered out before meteoric water is released into the sewerage system to such an extent that waste water contains:

Up to 5 mg of matter/litre - coalescence separators - S1P

Up to 100 mg of matter/litre - gravity separators - S2P

FUNCTION:

The separators operate under the principle of gravity. Oil, petrol, fuel oil, lubricants, heating oil and other light liquids have a lower specific weight than water, a fact exploited by oil and grease separators by reducing the velocity and flow of meteoric water, causing light-liquid particles to separate and rise to the surface. The filtered water thus flows safely through the drain into the sewerage system, protecting the groundwater from potential pollutants.

The following pages of the catalogue show the selection of typical oil separators, but if you require aid when choosing and ordering separators, adapted to the requirements of a construction site, you can contact our experts.

ADVANTAGES OF AQUAoil OIL AND GREASE SEPERATORS:

- They are manufactured and dimensioned in accordance with the SiST En 858, SiST En 1825 standard.
- They are certified using state-of-the-art testing methods.
- Light weight — easy to transport and install.
- Long life span (up to 50 years).
- They are made from polyethylene, which is especially suitable for recycling — environmentally friendly.
- Easy maintenance and servicing.
- Made in Slovenia.

SELECTION OF CATEGORY OF OIL SEPARATOR IN REGARDS TO INSTALLATION LOCATION:

The term "settler" marks the part of the separator, where the material settles. The table below shows the volume of the settler in regards to installation location (table from Standard SIST EN 858-1). The category is chosen by the planner.

Needed category of the oil separator	Use of the oil separator	Minimal volume of settler
Small	<ul style="list-style-type: none"> - Waste water with defined small sludge volume - All rainwater collecting areas where a small amount of silt from traffic or similar appears, i.e. catchment basins on petrol tank areas 	$(100 \times NS) / f_d$ a
Medium	<ul style="list-style-type: none"> - Filling stations, carwash by hand, bus wathing places - Waste water from garages, vehicle parking lots - Power plants, machinery plants 	$(200 \times NS) / f_d$ b
High	<ul style="list-style-type: none"> - Washing plants for site vehicles, farm machines - Truck wash places 	$(300 \times NS) / f_d$ b
	<ul style="list-style-type: none"> - Automatic car washes 	$(300 \times NS) / f_d$ c

a – Equation does not apply to soperators, smaller than NS 10, except for covered car parks
 b – Regardless of the equation, minimal volume of settler can't be smaller than 600l
 c – Regardless of the equation, minimal volume of setler can't be smaller than 5000l



1. AQUAoil gravity separators

Wastewater polluted with light liquids is retained inside the separator for a certain amount of time. Due to their lower specific weight, light liquids rise to the surface. The filtered water is drained from the separator through the outflow. Through correct use, light liquids accumulate inside the device, which must regularly be removed.

The gravity separators are suitable for removing light liquids also on **traffic areas**.

AQUAoil_S2P

Cat.	TYPE AQUAoil S2P Q (l/s)	SETTLER VOLUME (l)	TOTAL VOLUME (l)	PIPE CONNECTOR Ø (mm)	LENGTH L / L1 (max) (mm)	INFLOW / OUTFLOW H1 (mm) / H2 (mm)		HEIGHT H3 (mm)	DIAMETER DN (mm)	NO. REV. OPENINGS	MAX SURFACE (m ²)
Small	NS 1,5	* 150	300	110	800/1220	590	570	1250	800	1	70
Medium		* 300	700	110	1000/1420	840	820	1750	1000	1	70
High		* 450	800	110	1000/1420	1090	1070	2000	1000	1	70
Small	NS 3	* 300	800	110	1000/1420	1090	1070	2000	1000	1	200
Medium		* 600	1200	110	1000/1420	1590	1570	2500	1000	1	200
High		900	2000	110	1470/1870	1205	1185	1600	1400	1	200
Small	NS 6	600	2000	125	1470/1870	1205	1185	1600	1400	1	400
Medium		1200	3000	125	2550/2560	1205	1185	1600	1400	2	400
High		1800	3500	125	1850/2055	1530	1505	2000	1750	1	400
Small	NS 10	1000	3500	160	1850/2055	1530	1505	2000	1750	1	670
Medium		2000	5000	160	2450/2580	1530	1505	2000	1750	2	670
High		3000	6000	160	2900/3050	1530	1505	2000	1750	1	670
Small	NS 15	1500	5000	200	2450/2580	1530	1505	2000	1750	1	1000
Medium		3000	6000	200	2900/3050	1530	1505	2000	1750	1	1000
High		4500	7000	200	3350/3610	1530	1505	2000	1750	1	1000
Small	NS 20	2000	6000	200	2900/3050	1530	1505	2000	1750	1	1400
Medium		4000	7000	200	3350/3610	1530	1505	2000	1750	1	1400
High		6000	10000	200	4950/5600	1530	1505	2000	1750	2	1400
Small	NS 30	3000	8000	250	4020/4420	1530	1505	2000	1750	2	2000
Medium		6000	10000	250	4950/5600	1530	1505	2000	1750	2	2000
High		9000	12000	250	5870/6400	1530	1505	2000	1750	2	2000
Small	NS 40	4000	10000	315	4950/5600	1530	1505	2000	1750	2	2700
Medium		8000	16000	315	4860/5600	1920	1870	2600	2300	2	2700
High		12000	18000	315	5350/6100	1920	1870	2600	2300	2	2700
Small	NS 50	5000	12000	315	5870/6400	1530	1505	2000	1750	2	3400
Medium		10000	18000	315	5350/6100	1920	1870	2600	2300	2	3400
High		15000	22000	315	6595/7350	1920	1870	2600	2300	3	3400
Small	NS 60	6000	16000	315	4860/5600	1920	1870	2600	2300	2	4000
Medium		12000	22000	315	6595/7350	1920	1870	2600	2300	3	4000
High		18000	28000	315	8065/8800	1920	1870	2600	2300	3	4000

*Vertical version

AQUAoil_S2P

Cat.	TYPE AQUAoil S2P Q (l/s)	SETTLER VOLUME (l)	TOTAL VOLUME (l)	PIPE CONNECTOR Ø (mm)	LENGTH L / L1 (max) (mm)	INFLOW / OUTFLOW H1 (mm) / H2 (mm)		HEIGHT H3 (mm)	DIAMETER DN (mm)	NO. REV. OPENINGS	MAX SURFACE (m ²)
Small	NS 80	7500	20000	315	5840/6550	1920	1870	2600	2300	2	5400
Medium		15000	28000	315	8065/8800	1920	1870	2600	2300	3	5400
High		22500	36000	315	10295/11050	1920	1870	2600	2300	3	5400
Small	NS 100	10000	24000	315	7085/7850	1920	1870	2600	2300	3	6700
Medium		20000	36000	315	10295/11050	1920	1870	2600	2300	3	6700
High		30000	46000	315	13015/13600	1920	1870	2600	2300	3	6700
Small	NS 150	15000	36000	400	10295/11050	1920	1870	2600	2300	3	10000
Medium		** 30000	30000+ 20000	400	15300/16000	1920	1850	2600	2300	4	10000
High		** 45000	46000+ 20000	400	18850/19500	1920	1850	2600	2300	5	10000
Small	NS 200	20000	46000	400	13015/13600	1920	1850	2600	2300	3	13400
Medium		** 40000	40000+ 30000	400	20700/21400	1920	1850	2600	2300	4	13400
High		** 60000	46000+ 40000	400	25250/25900	1920	1850	2600	2300	5	13400
Small	NS 250	** 25000	26000+ 30000	400	17077/17800	1920	1850	2600	2300	5	16700
Medium		** 50000	46000+ 30000	400	22500/23200	1920	1850	2600	2300	5	16700
High		** 75000	2x40000+ 40000	400	35600/36250	1970	1850	2600	2300	6	16700
Small	NS 300	** 30000	30000+ 30000	400	18000/18650	1970	1850	2600	2300	4	20100
Medium		** 60000	2x30000+ 40000	400	30200/30850	1970	1850	2600	2300	6	20100
High		** 90000	1x46000+ 1x40000+ 1x46000	400	39250/39900	1970	1850	2600	2300	8	20100

**Composed version

- Max. surface area calculated for a rainfall intensity of 150l/(s ha) with the infiltration time of T max. = 3min
- Option version with automatic closing for all types (SIST 858-1 (6.5.3))
- Option version with oil level sensor (SIST 851-1 (6.5.4))

AQUAoil S2P (vertical version)

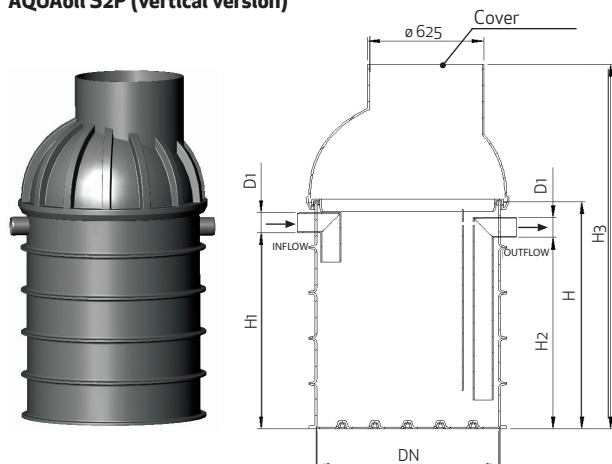

AQUAoil S2P (horizontal version)

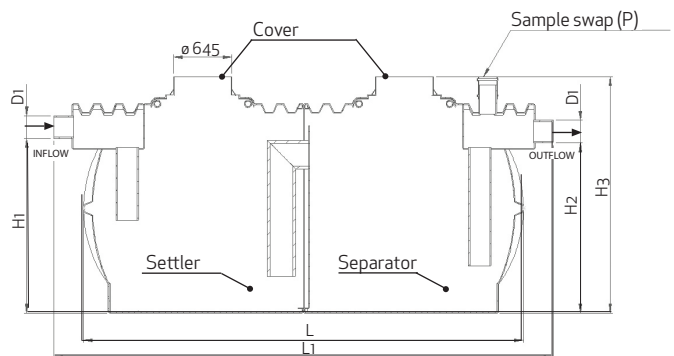

• Images are symbolic and don't represent actual form of oil separators.

2. AQUAoil coalescence separators

They function in a similar manner to the gravity separators. Their specialty is a coalescing filter which filters small hydrocarbon molecules, which cannot be removed using gravity, as due to their small size, they do not remain at the surface regardless of their buoyancy. In the coalescing unit, hydrocarbon molecules adhere to the coalescing material, bind into a thin layer and, upon reaching an adequate size, rise, with the help of buoyancy, to the surface of the wastewater.

AQUAoil_S1P

Cat.	TYPE AQUAoil S1P Q (l/s)	SETTLER VOLUME (l)	TOTAL VOLUME (l)	PIPE CONNECTOR Ø (mm)	LENGTH L / L1 (max) (mm)	INFLOW / OUTFLOW H1 (mm) / H2 (mm)		HEIGHT H3 (mm)	DIAMETER DN (mm)	NO. REV. OPENINGS	MAX SURFACE (m ²)
Small	NS 1,5	* 150	300	110	800/1220	590	570	1250	800	1	70
Medium		* 300	700	110	1000/1420	840	820	1750	1000	1	70
High		* 450	800	110	1000/1420	1090	1070	2000	1000	1	70
Small	NS 3	* 300	800	110	1000/1420	1090	1070	2000	1000	1	200
Medium		* 600	1200	110	1000/1420	1590	1570	2500	1000	1	200
High		900	2000	110	1470/1870	1205	1185	1600	1400	1	200
Small	NS 6	600	2000	125	1470/1870	1205	1185	1600	1400	1	400
Medium		1200	3000	125	2550/2560	1205	1185	1600	1400	2	400
High		1800	3500	125	1850/2055	1530	1505	2000	1750	1	400
Small	NS 10	1000	3500	160	1850/2055	1530	1505	2000	1750	1	670
Medium		2000	5000	160	2450/2580	1530	1505	2000	1750	2	670
High		3000	6000	160	2900/3050	1530	1505	2000	1750	1	670
Small	NS 15	1500	5000	200	2450/2580	1530	1505	2000	1750	1	1000
Medium		3000	6000	200	2900/3050	1530	1505	2000	1750	1	1000
High		4500	7000	200	3350/3610	1530	1505	2000	1750	1	1000
Small	NS 20	2000	6000	200	2900/3050	1530	1505	2000	1750	1	1400
Medium		4000	7000	200	3350/3610	1530	1505	2000	1750	1	1400
High		6000	10000	200	4950/5600	1530	1505	2000	1750	2	1400
Small	NS 30	3000	8000	250	4020/4420	1530	1505	2000	1750	2	2000
Medium		6000	10000	250	4950/5600	1530	1505	2000	1750	2	2000
High		9000	12000	250	5870/6400	1530	1505	2000	1750	2	2000
Small	NS 40	4000	10000	315	4950/5600	1530	1505	2000	1750	2	2700
Medium		8000	16000	315	4860/5600	1920	1870	2600	2300	2	2700
High		12000	18000	315	5350/6100	1920	1870	2600	2300	2	2700
Small	NS 50	5000	12000	315	5870/6400	1530	1505	2000	1750	2	3400
Medium		10000	18000	315	5350/6100	1920	1870	2600	2300	2	3400
High		15000	22000	315	6595/7350	1920	1870	2600	2300	3	3400
Small	NS 60	6000	16000	315	4860/5600	1920	1870	2600	2300	2	4000
Medium		12000	22000	315	6595/7350	1920	1870	2600	2300	3	4000
High		18000	28000	315	8065/8800	1920	1870	2600	2300	3	4000

*Vertical version

AQUAoil_S1P

Cat.	TYPE AQUAoil S1P Q (l/s)	SETTLER VOLUME (l)	TOTAL VOLUME (l)	PIPE CONNECTOR Ø (mm)	LENGTH L / L1 (max) (mm)	INFLOW / OUTFLOW H1 (mm) / H2 (mm)		HEIGHT H3 (mm)	DIAMETER DN (mm)	NO. REV. OPENINGS	MAX SURFACE (m ²)
Small	NS 80	7500	20000	315	5840/6550	1920	1870	2600	2300	2	5400
Medium		15000	28000	315	8065/8800	1920	1870	2600	2300	3	5400
High		22500	36000	315	10295/11050	1920	1870	2600	2300	3	5400
Small	NS 100	10000	24000	315	7085/7850	1920	1870	2600	2300	3	6700
Medium		20000	36000	315	10295/11050	1920	1870	2600	2300	3	6700
High		30000	46000	315	13015/13600	1920	1870	2600	2300	3	6700
Small	NS 150	15000	36000	400	10295/11050	1920	1870	2600	2300	3	10000
Medium		** 30000	30000+ 20000	400	15300/16000	1920	1850	2600	2300	4	10000
High		** 45000	46000+ 20000	400	18850/19500	1920	1850	2600	2300	5	10000
Small	NS 200	20000	46000	400	13015/13600	1920	1850	2600	2300	3	13400
Medium		** 40000	40000+ 30000	400	20700/21400	1920	1850	2600	2300	4	13400
High		** 60000	46000+ 40000	400	25250/25900	1920	1850	2600	2300	5	13400
Small	NS 250	** 25000	26000+ 30000	400	17077/17800	1920	1850	2600	2300	5	16700
Medium		** 50000	46000+ 30000	400	22500/23200	1920	1850	2600	2300	5	16700
High		** 75000	2x40000+ 40000	400	35600/36250	1970	1850	2600	2300	6	16700
Small	NS 300	** 30000	30000+ 30000	400	18000/18650	1970	1850	2600	2300	4	20100
Medium		** 60000	2x30000+ 40000	400	30200/30850	1970	1850	2600	2300	6	20100
High		** 90000	1x46000+ 1x40000+ 1x46000	400	39250/39900	1970	1850	2600	2300	8	20100

**Composed version

- Max. surface area calculated for a rainfall intensity of 150l/(s ha) with the infiltration time of T max. = 3min
- Option version with automatic closing for all types (SIST 858-1 (6.5.3))
- Option version with oil level sensor (SIST 851-1 (6.5.4))



AQUAoil S1P (vertical version)

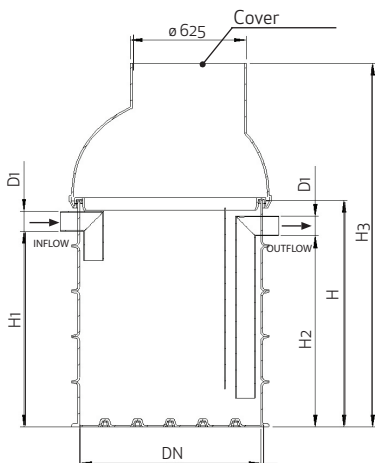

AQUAoil S1P (horizontal version)

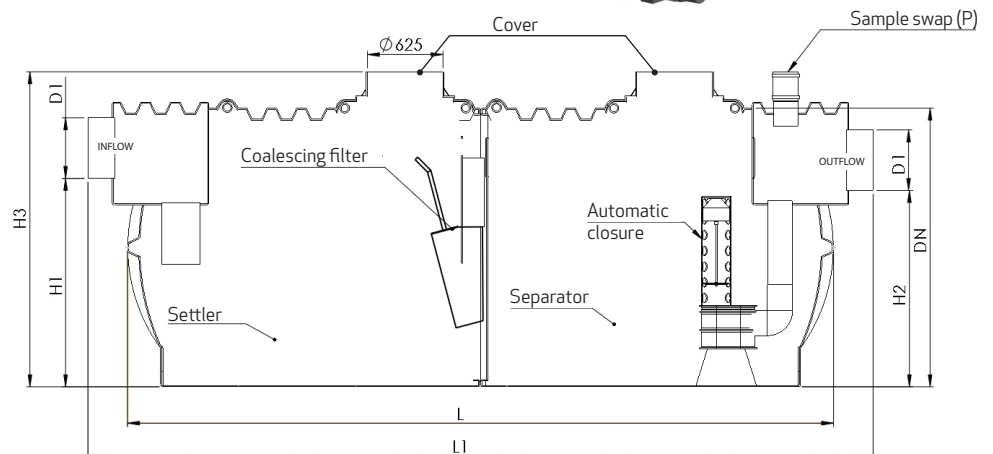

• Images are symbolic and don't represent actual form of oil separators.

3. AQUAoil coalescence separators with a bypass

Bypass separators are used to purify wastewater on large road surfaces with dense moving or static traffic. It is especially appropriate where light liquids, or fuel residues, accumulate on the surface due to the traffic (public roads, motorways, car parks and multi-storey car parks). During heavy rainfalls, light liquids begin to accumulate and flow into the separator, where the oils are separated, and the surplus of purified meteoric water flows out through the bypass, which prevents surface flooding. Bypass separators are available with a bypass with a 10% flow rate and with a 20% flow rate.

3.1. AQUAoil coalescence separators with a bypass with a 10% flow rate

AQUAoil S1P-BP

Cat.	TYPE AQUAoil S1P-BP	FLOW DATA		TYPE OF BYPASS	PIPE CONNECTION Φ (mm)	LENGTH L / L1 (max) (mm)	INFLOW / OUTFLOW H1 (mm) / H2 (mm)		HEIGHT H3 (mm)	DIAMETER DN (mm)	NO. REV. OPENINGS	MAX SURFACE (m ²)
Medium	*15/1,5	Flow	1,5l/s	Internal	200	1000/1400	970	940	2000	800	1	1000
		Settler	300l									
		Total vol.	800l									
Small	*30/3	Flow	3l/s	Internal	250	1000/1400	1170	1140	2250	1000	1	2000
		Settler	300l									
		Total vol.	1000l									
Medium	*30/3	Flow	3l/s	Internal	250	1000/1400	1420	1390	2500	1000	1	2000
		Settler	600l									
		Total vol.	1200l									
Small	50/5	Flow	5l/s	External	315	1650/2380	1300	1250	1850	1400	1	4000
		Settler	500l									
		Total vol.	2000l									
Medium	50/5	Flow	5l/s	External	315	1950/2750	1300	1250	1850	1750	1	4000
		Settler	1000l									
		Total vol.	2500l									
Small	60/6	Flow	6l/s	External	315	1650/2380	1300	1250	1850	1400	1	4000
		Settler	600l									
		Total vol.	2000l									
Medium	60/6	Flow	6l/s	External	315	1950/2750	1300	1250	1850	1750	1	4000
		Settler	1200l									
		Total vol.	2500l									
Small	80/8	Flow	8l/s	External	315	1950/2750	1300	1250	1850	1750	1	5400
		Settler	800l									
		Total vol.	2500l									
Medium	80/8	Flow	8l/s	External	315	1800/2800	1530	1480	2000	1750	1	5400
		Settler	1600l									
		Total vol.	3500l									
Small	100/10	Flow	10l/s	External	400	1800/2800	1530	1480	2000	1750	1	6700
		Settler	1000l									
		Total vol.	3500l									

*Vertical version (look at the picture on page 7)

AQUAoil S1P-BP

Cat.	TYPE AQUAoil S1P-BP	FLOW DATA		TYPE OF BYPASS	PIPE CONNECTION Φ (mm)	LENGTH L / L1 (max) (mm)	INFLOW / OUTFLOW H1 (mm) / H2 (mm)		HEIGHT H3 (mm)	DIAMETER DN (mm)	NO. REV. OPENINGS	MAX. SURFACE (m ²)
		Flow	10l/s				H1 (mm)	H2 (mm)				
Medium	100/10	Flow	10l/s	External	400	3400/4600	1530	1480	2000	1750	1	6700
		Settler	2000l									
		Total vol.	7000l									
Small	150/15	Flow	15l/s	External	400	1800/2800	1530	1480	2000	1750	1	10000
		Settler	1500l									
		Total vol.	3500l									
Medium	150/15	Flow	15l/s	External	400	3400/4600	1530	1480	2000	1750	1	10000
		Settler	3000l									
		Total vol.	7000l									
Small	200/20	Flow	20l/s	External	400	2950/4200	1530	1480	2000	1750	1	13400
		Settler	2000l									
		Total vol.	6000l									
Medium	200/20	Flow	20l/s	External	400	4000/5200	1530	1480	2000	1750	2	13400
		Settler	4000l									
		Total vol.	8000l									
Small	300/30	Flow	30l/s	External	500	2900/4100	1530	1480	2000	1750	2	20000
		Settler	3000l									
		Total vol.	6000l									
Medium	300/30	Flow	30l/s	External	500	4950/5950	1530	1480	2000	1750	2	20000
		Settler	6000l									
		Total vol.	10000l									
Small	400/40	Flow	40l/s	External	500	4000/5200	1530	1480	2000	1750	2	26500
		Settler	4000l									
		Total vol.	8000l									
Medium	400/40	Flow	40l/s	Internal	500	4850/5600	1650	1550	2600	2300	2	26500
		Settler	8000l									
		Total vol.	16000l									
Small	500/50	Flow	50l/s	External	630	3900/4600	1650	1550	2600	1750	2	33200
		Settler	5000l									
		Total vol.	12000l									
Medium	500/50	Flow	50l/s	Internal	630	5850/6600	1720	1620	2600	2300	2	33200
		Settler	10000l									
		Total vol.	20000l									
Small	600/60	Flow	60l/s	External	630	3900/4600	1650	1550	2600	1750	2	40000
		Settler	6000l									
		Total vol.	12000l									

AQUAoil S1P-BP

Cat.	TYPE AQUAoil S1P-BP	FLOW DATA		TYPE OF BYPASS	PIPE CONNECTION Φ (mm)	LENGTH L / L1 (max) (mm)	INFLOW / OUTFLOW H1 (mm) / H2 (mm)		HEIGHT H3 (mm)	DIAMETER DN (mm)	NO. REV. OPENINGS	MAX. SURFACE (m ²)
		Flow	Settler				Total vol.					
Medium	600/60	Flow	60l/s	Internal	630	5850/6600	1720	1620	2600	2300	2	40000
		Settler	12000l									
		Total vol.	20000l									
Small	700/70	Flow	70l/s	Internal	800	4850/5600	1650	1550	2600	2300	2	46600
		Settler	7000l									
		Total vol.	16000l									
Medium	700/70	Flow	70l/s	Internal	800	8100/8800	1650	1550	2600	2300	3	46600
		Settler	14000l									
		Total vol.	28000l									
Small	800/80	Flow	80l/s	Internal	800	4850/5600	1650	1550	2600	2300	2	53400
		Settler	8000l									
		Total vol.	16000l									
Medium	800/80	Flow	80l/s	Internal	800	8100/8800	1650	1550	2600	2300	3	53400
		Settler	16000l									
		Total vol.	28000l									
Small	1000/100	Flow	100l/s	Internal	800	5350/6100	1650	1550	2600	2300	2	66000
		Settler	10000l									
		Total vol.	18000l									
Medium	1000/100	Flow	100l/s	Internal	800	10300/11000	1650	1550	2600	2300	3	66000
		Settler	20000l									
		Total vol.	36000l									
Small	1250/125	Flow	125l/s	Internal	800	7600/8300	1650	1550	2600	2300	3	83400
		Settler	12500l									
		Total vol.	26000l									
Medium	1250/125	Flow	125l/s	Internal	800	13000/13600	1650	1550	2600	2300	3	83400
		Settler	25000l									
		Total vol.	46000l									

External bypass

AQUAoil S1P 50/5 - 600/60*

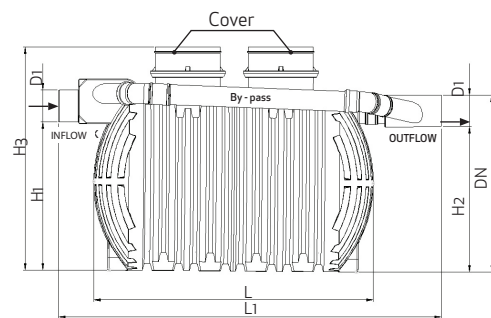
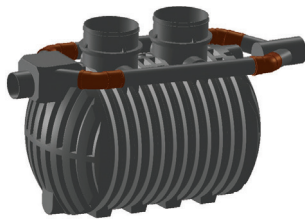

Internal bypass

AQUAoil S1P 400/40 - 1250/125*

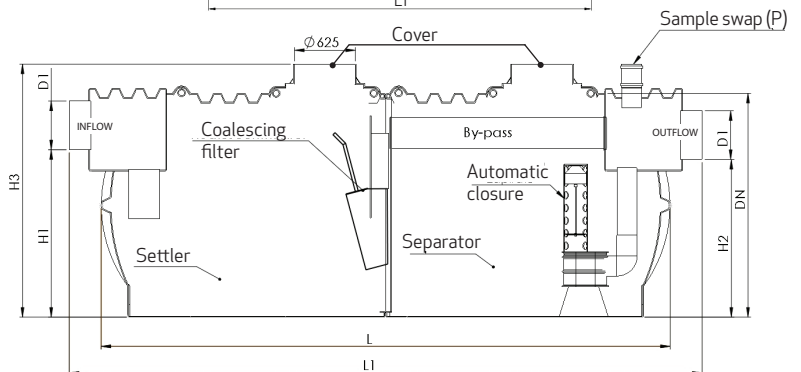
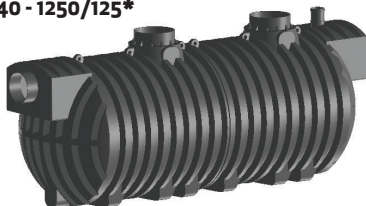

*Type of bypass for each oil separator is listed in the table.

• Images are symbolic and don't represent actual form of oil separators.

3.2. AQUAoil coalescence separators with a bypass with a 20% flow rate

AQUAoil S1P-BP

Cat.	TYPE AQUAoil S1P-BP	FLOW DATA		TYPE OF BYPASS	PIPE CONNECTION Φ (mm)	LENGTH L / L1 (max) (mm)	INFLOW / OUTFLOW H1 (mm) /H2 (mm)		HEIGHT H3 (mm)	DIAMETER DN (mm)	NO. REV. OPENINGS	MAX. SURFACE (m ²)
		Flow	Settler									
Medium	* 15/3	Flow	3l/s	Internal	250	1000/1400	1170	1140	2250	1000	1	1000
		Settler	600l									
		Total vol.	1000l									
Small	* 30/6	Flow	6l/s	Internal	315	1000/1400	1355	1325	2500	1000	1	2000
		Settler	600l									
		Total vol.	1200l									
Medium	30/6	Flow	6l/s	External	315	1650/2380	1300	1250	1850	1400	1	2000
		Settler	1200l									
		Total vol.	2000l									
Small	50/10	Flow	10l/s	External	400	1950/2750	1300	1250	1850	1750	1	4000
		Settler	1000l									
		Total vol.	2500l									
Medium	50/10	Flow	10l/s	External	400	1800/2800	1530	1480	2000	1750	1	4000
		Settler	2000l									
		Total vol.	3500l									
Small	60/12	Flow	12l/s	External	400	1950/2750	1300	1250	1850	1750	1	4000
		Settler	1200l									
		Total vol.	2500l									
Medium	60/12	Flow	12l/s	External	400	1800/2800	1530	1480	2000	1750	1	4000
		Settler	2400l									
		Total vol.	3500l									
Small	80/16	Flow	16l/s	External	400	1800/2800	1530	1480	2000	1750	1	5400
		Settler	1600l									
		Total vol.	3500l									
Medium	80/16	Flow	16l/s	External	400	2950/4200	1530	1480	2000	1750	1	5400
		Settler	3200l									
		Total vol.	6000l									
Small	100/20	Flow	20L/s	External	500	3400/4150	1530	1480	2000	1750	1	6700
		Settler	2000l									
		Total vol.	7000l									
Medium	100/20	Flow	20l/s	External	500	4950/5950	1530	1480	2000	1750	2	6700
		Settler	4000l									
		Total vol.	10000l									
Small	150/30	Flow	30l/s	External	500	3400/4150	1530	1480	2000	1750	1	10000
		Settler	3000l									
		Total vol.	7000l									

*Vertical version

AQUAoil S1P-BP

Cat.	TYPE AQUAoil S1P-BP	FLOW DATA		TYPE OF BYPASS	PIPE CONNECTION Φ (mm)	LENGTH L / L1 (max) (mm)	INFLOW / OUTFLOW H1 (mm) /H2 (mm)		HEIGHT H3 (mm)	DIAMETER DN (mm)	NO. REV. OPENINGS	MAX. SURFACE (m ²)
		Flow	Settler									
Medium	150/30	Flow	30l/s	External	500	4950/5950	1530	1480	2000	1750	2	10000
		Settler	6000l									
		Total vol.	10000l									
Small	200/40	Flow	40l/s	External	500	4000/5050	1530	1480	2000	1750	2	13400
		Settler	4000l									
		Total vol.	8000l									
Medium	200/40	Flow	40l/s	Internal	500	4850/5600	1650	1550	2600	2300	2	13400
		Settler	8000l									
		Total vol.	16000l									
Small	300/60	Flow	60l/s	External	630	4950/5950	1530	1480	2000	1750	2	20000
		Settler	6000l									
		Total vol.	10000l									
Medium	300/60	Flow	60l/s	Internal	630	5850/6600	1720	1620	2600	2300	2	20000
		Settler	12000l									
		Total vol.	20000l									
Small	400/80	Flow	80l/s	Internal	800	4500/5600	1650	1550	2600	2300	2	26500
		Settler	8000l									
		Total vol.	16000l									
Medium	400/80	Flow	80l/s	Internal	800	8100/8800	1650	1550	2600	2300	3	26500
		Settler	16000l									
		Total vol.	28000l									
Small	500/100	Flow	100l/s	Internal	800	5850/6600	1720	1620	2600	2300	2	33200
		Settler	10000l									
		Total vol.	20000l									
Medium	500/100	Flow	100l/s	Internal	800	13000/13600	1600	1500	2600	2300	3	33200
		Settler	20000l									
		Total vol.	46000l									
Small	600/120	Flow	120l/s	Internal	800	5850/6600	1720	1620	2600	2300	2	40000
		Settler	12000l									
		Total vol.	20000l									
Medium	600/120	Flow	120l/s	Internal	800	13000/13600	1600	1500	2600	2300	3	40000
		Settler	24000l									
		Total vol.	46000l									
Small	700/140	Flow	140l/s	Internal	800	8100/8800	1650	1550	2600	2300	3	46600
		Settler	14000l									
		Total vol.	28000l									
Medium	700/140	Flow	140l/s	Internal	800	17100/17800	1650	1550	2600	2300	5	46600
		Settler	28000l									
		Total vol.	36000+20000l									

AQUAoil S1P-BP

Cat.	TYPE AQUAoil S1P-BP	FLOW DATA		TYPE OF BYPASS	PIPE CONNECTION Φ (mm)	LENGTH L / L1 (max) (mm)	INFLOW / OUTFLOW H1 (mm) / H2 (mm)		HEIGHT H3 (mm)	DIAMETER DN (mm)	NO. REV. OPENINGS	MAX. SURFACE (m ²)
		Flow	Settler				Total vol.	H1				
Small	800/160	Flow	160l/s	Internal	800	8100/8800	1650	1550	2600	2300	3	53400
		Settler	16000l									
		Total vol.	28000l									
Medium	800/160	Flow	160l/s	Internal	800	17100/17800	1650	1550	2600	2300	5	53400
		Settler	32000l									
		Total vol.	36000+20000l									
Small	1000/200	Flow	200l/s	Internal	800	10300/11000	1650	1550	2600	2300	3	66000
		Settler	20000l									
		Total vol.	36000l									
Medium	1000/200	Flow	200l/s	Internal	800	19800/20500	1650	1550	2600	2300	5	66000
		Settler	32000l									
		Total vol.	36000+30000l									
Small	1250/250	Flow	250l/s	Internal	800	13000/13600	1650	1550	2600	2300	3	83400
		Settler	25000l									
		Total vol.	46000l									
Medium	1250/250	Flow	250l/s	Internal	800	25300/25900	1650	1550	2600	2300	5	83400
		Settler	50000l									
		Total vol.	46000+40000l									

- Max. surface area calculated for a rainfall intensity of 150l/(s ha) with the infiltration time of T max. = 3min
- Option version with automatic closing for all types (SIST 858-1 (6.5.3))
- Option version with oil level sensor (SIST 851-1 (6.5.4))

External bypass

AQUAoil S1P 30/6 - 300/60*

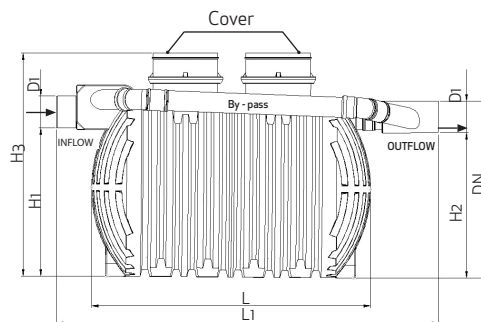
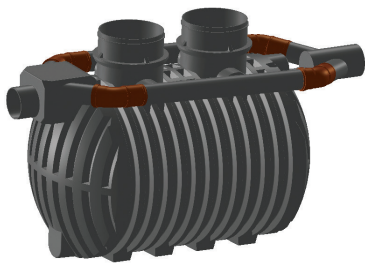

Internal bypass

AQUAoil S1P 200/40 - 1250/250*

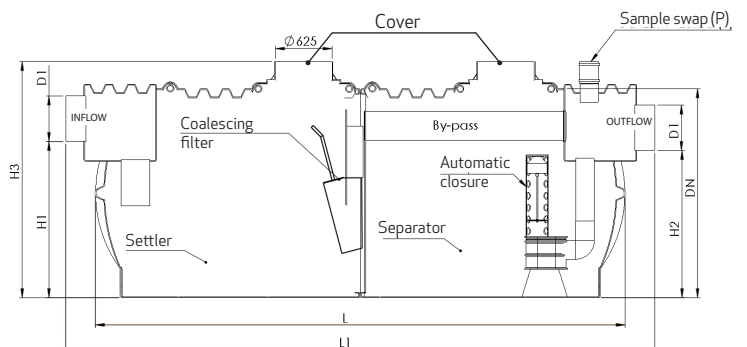
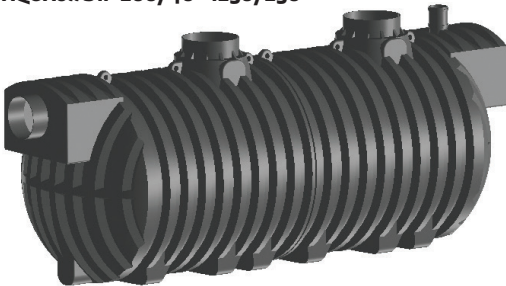

- *Type of bypass for each type of separator is listed in the table.
- Images are symbolic and don't represent actual form of oil separators.

4. Means of installation in case of automatic closure device

a) Picture below represents installation systems.

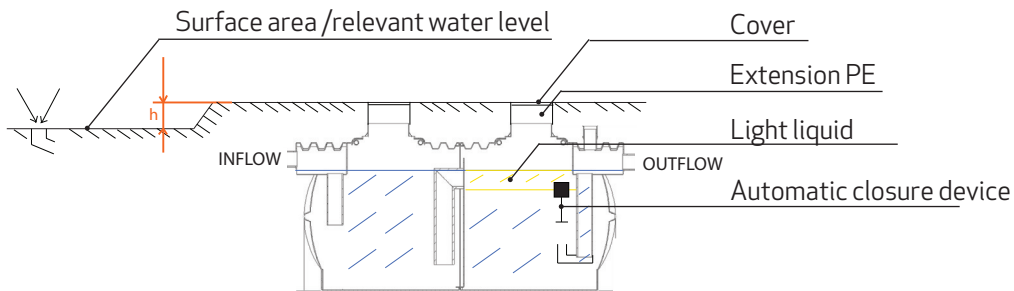

b) Maximum storage capacity is reached. Automatic closure device closes and stops further effluents.

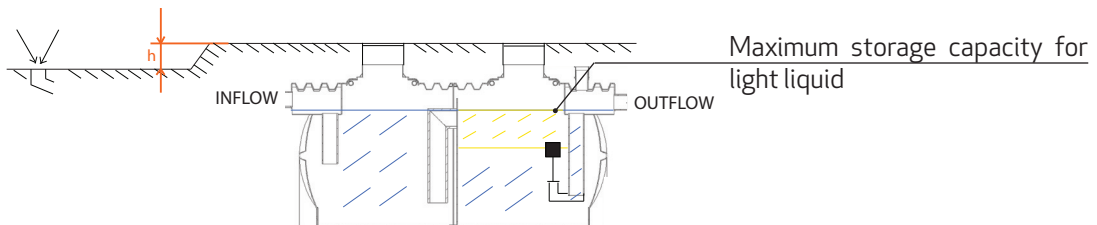

c) Additional waste water raises the liquid level in the system, until the lowest installed drain is reached. The light liquid level in the extension shaft is higher than the corresponding water level in drainage system. For protection against the overflow of light liquid the level of the covers (of the extension shaft) shall be higher than the relevant level of the drains.

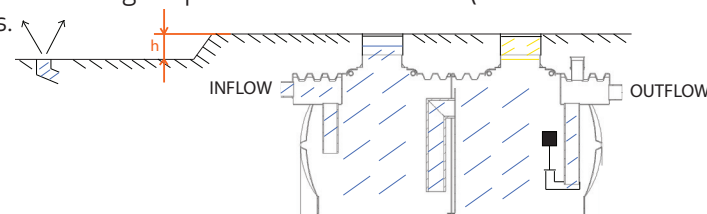

d) Cover below relevant level. Installation protection by a warning device to prevent the situation shown in point e.

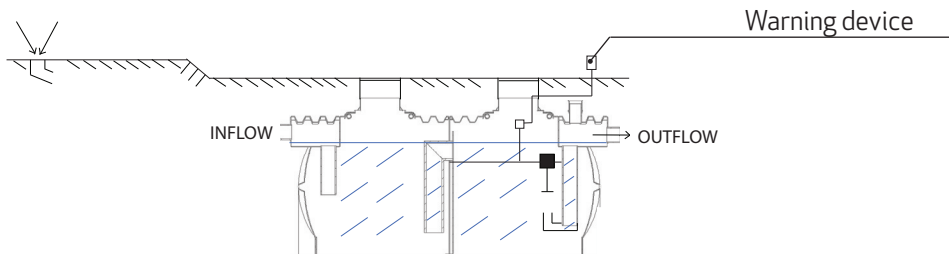

e) Closed automatic closure device causes the overflow of light liquid out of the extension pieces.

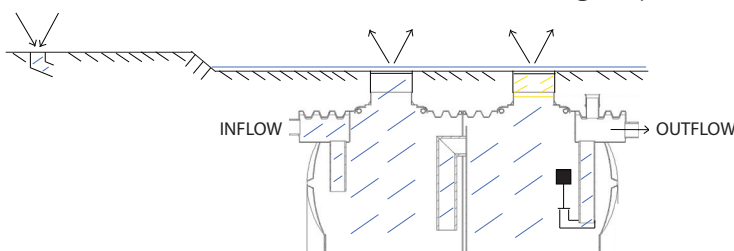

5. AQUAoil grease separators

It is especially suitable for restaurants, which are subject to the statutory separation of greases and oils of organic origin before wastewater is drained into the sewer, before it reaches a cesspit or treatment plant. The separator functions by retaining organic matter from the wastewater before it is drained into the sewerage system.

AQUAoil NS_S 2P - GR

Cat.	TYPE AQUAoil S2P GR Q (l/s)	TOTAL VOLUME (l)	PIPE CONNECTOR Ø (mm)	LENGTH L (mm)	INFLOW / OUTFLOW H1 (mm) / H2 (mm)		HEIGHT H3 (mm)	DIAMETER DN (mm)	NO. REV. OPENINGS	NO. OF RATIONS (ration/day)
1	* 1	450	110	1000	830	802	1250-1500	800	1	100
2	* 2	600	110	750	690	665	1500-1750	1000	1	200
3	* 3	1000	110	1250	1080	1055	1750-2000	1000	1	300
4	4	1800	110	1640	1260	1210	1600	1400	1	400
6	6	2500	125	1940	1250	1200	1600	1400	1	600
10	10	3500	160	1800	1575	1550	2000	1750	1	1000
15	15	5500	200	2700	1540	1515	2000	1750	2	1500
20	20	7500	200	3600	1540	1515	2000	1750	2	2000
25	25	10000	200	4500	1540	1515	2000	1750	2	2500

*Vertical version

- Max. surface area calculated for a rainfall intensity of 150l/(s ha) with a dwell time of T max. = 3min
- Option version with automatic closing for all types

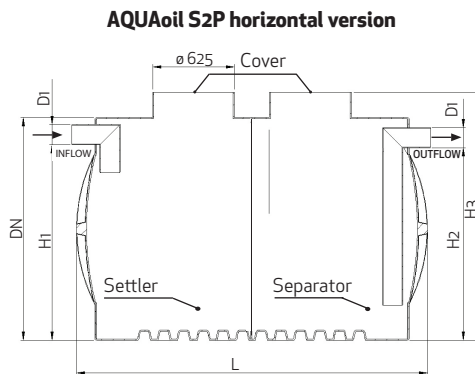
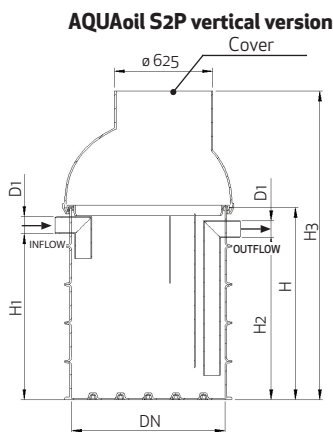

- Images are symbolic and don't represent actual form of grease separators.



6. Accessories



Oil level sensor

The oil level sensor is a device with two probes. Should the oil level reach 90% of separator volume, the device warns us with a sound and visual signal.

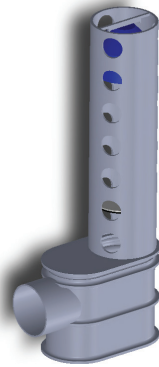

Automatic closure

Automatic closure prevents oil from overflowing from the separator if there is a possibility that there is too much oil which could flow into the outflow pipe.



Oil level measuring gauge



Sampling pump

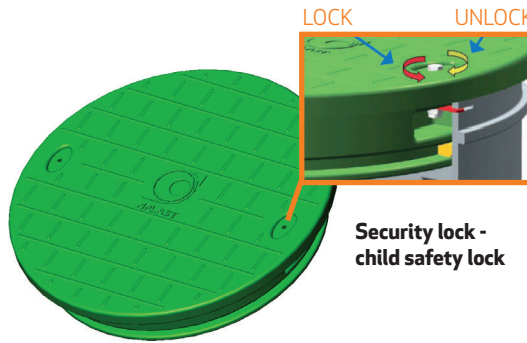

PE covers FI 625

Security lock - child safety lock

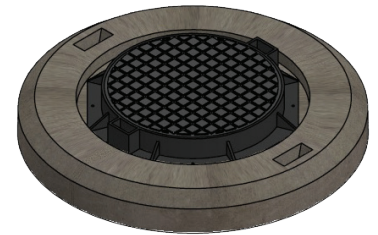

Cast iron covers with AB ring (class A to D)



Ring PE fi 625/250



Ring PE fi 625/500

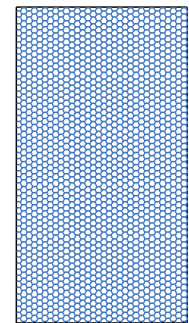

Coalescence filters

When installing and maintaining AQUAoil oil and grease separators please strictly follow the instructions of the manufacturer! Instructions for installation and maintenance can also be found on our website: www.aplast.si



Lined writing area consisting of 20 horizontal orange lines.

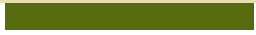





APLAST proizvodnja in trgovina d.o.o.
Petrovče 115a, 3301 Petrovče, Slovenija
www.aplast.si | info@aplast.si



YOUR RETAILER: